

Write your name here

Surname

Other names

**Pearson Edexcel  
International GCSE**

Centre Number

--	--	--	--	--

Candidate Number

--	--	--	--

# Mathematics A

## Paper 4HR



**Higher Tier**

Thursday 9 June 2016 – Morning  
**Time: 2 hours**

Paper Reference

**4MA0/4HR**

**You must have:**

Ruler graduated in centimetres and millimetres, protractor, compasses, pen, HB pencil, eraser, calculator. Tracing paper may be used.

Total Marks

--

### Instructions

- Use **black** ink or ball-point pen.
- **Fill in the boxes** at the top of this page with your name, centre number and candidate number.
- Answer **all** questions.
- Without sufficient working, correct answers may be awarded no marks.
- Answer the questions in the spaces provided  
– *there may be more space than you need.*
- **Calculators may be used.**
- You must **NOT** write anything on the formulae page.  
Anything you write on the formulae page will gain NO credit.

### Information

- The total mark for this paper is 100.
- The marks for **each** question are shown in brackets  
– *use this as a guide as to how much time to spend on each question.*

### Advice

- Read each question carefully before you start to answer it.
- Check your answers if you have time at the end.

Turn over ►

P46228A

©2016 Pearson Education Ltd.

1/1/1/



**PEARSON**

**International GCSE MATHEMATICS  
FORMULAE SHEET – HIGHER TIER**

Pythagoras' Theorem

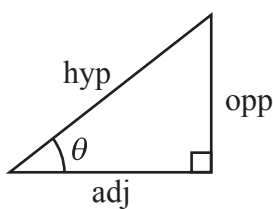
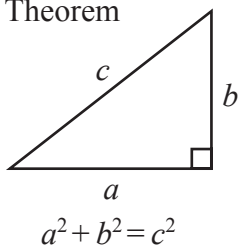

adj = hyp  $\times$  cos  $\theta$   
opp = hyp  $\times$  sin  $\theta$   
opp = adj  $\times$  tan  $\theta$

or  $\sin \theta = \frac{\text{opp}}{\text{hyp}}$

$\cos \theta = \frac{\text{adj}}{\text{hyp}}$

$\tan \theta = \frac{\text{opp}}{\text{adj}}$

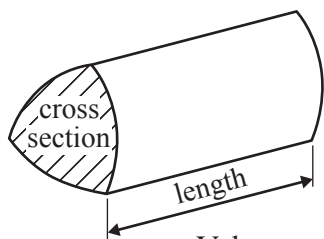

Volume of prism = area of cross section  $\times$  length

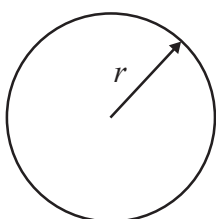

Circumference of circle =  $2\pi r$

Area of circle =  $\pi r^2$

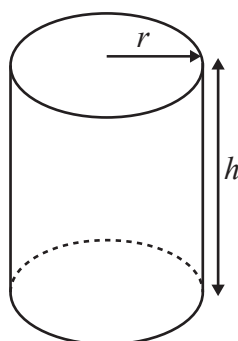

Volume of cylinder =  $\pi r^2 h$

Curved surface area of cylinder =  $2\pi r h$

Volume of cone =  $\frac{1}{3} \pi r^2 h$

Curved surface area of cone =  $\pi r l$

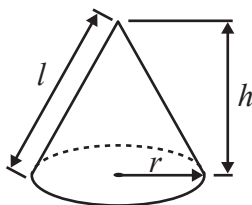

Volume of sphere =  $\frac{4}{3} \pi r^3$

Surface area of sphere =  $4\pi r^2$

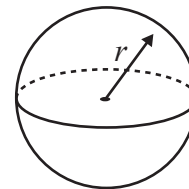

In any triangle ABC

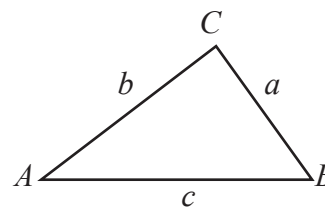

Sine rule:  $\frac{a}{\sin A} = \frac{b}{\sin B} = \frac{c}{\sin C}$

Cosine rule:  $a^2 = b^2 + c^2 - 2bc \cos A$

Area of triangle =  $\frac{1}{2} ab \sin C$

Area of a trapezium =  $\frac{1}{2}(a + b)h$

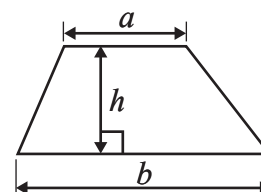

The Quadratic Equation

The solutions of  $ax^2 + bx + c = 0$ , where  $a \neq 0$ , are given by

$$x = \frac{-b \pm \sqrt{b^2 - 4ac}}{2a}$$

DO NOT WRITE IN THIS AREA

DO NOT WRITE IN THIS AREA

DO NOT WRITE IN THIS AREA



DO NOT WRITE IN THIS AREA

DO NOT WRITE IN THIS AREA

DO NOT WRITE IN THIS AREA

Answer ALL TWENTY ONE questions.

Write your answers in the spaces provided.

You must write down all the stages in your working.

1

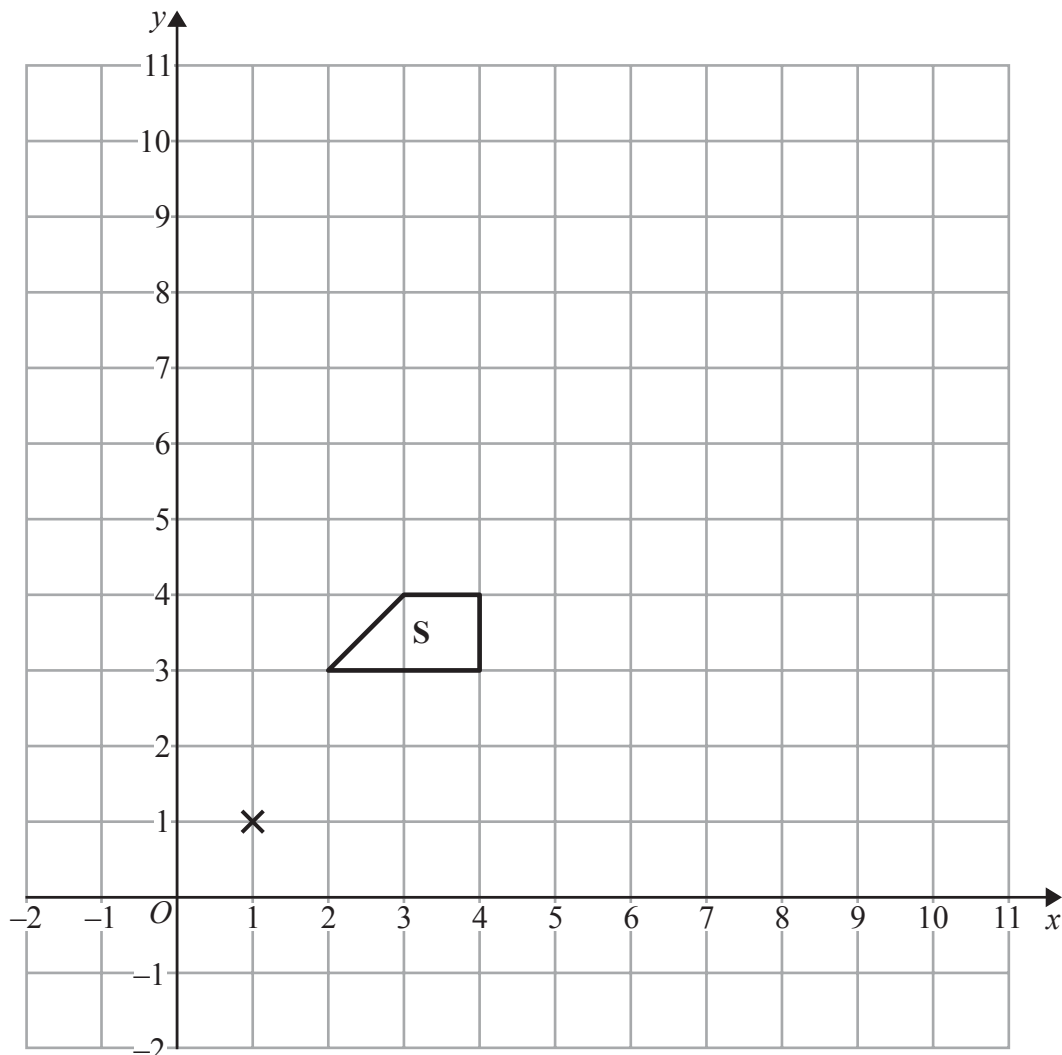

- (a) Enlarge shape **S**, by scale factor 2, centre (1, 1).  
Label the new shape **T**.

(2)

- (b) Describe fully the single transformation that maps shape **T** onto shape **S**.

(1)

(Total for Question 1 is 3 marks)



- 2 (a) Solve  $6t - 5 = 2t + 9$   
Show clear algebraic working.

$$t = \dots\dots\dots (3)$$

- (b) Expand and simplify  $3(2y + 2) + 2(y - 4)$

$$\dots\dots\dots (2)$$

- (c) Simplify fully  $4wxy \div (8xy)$

$$\dots\dots\dots (2)$$

**(Total for Question 2 is 7 marks)**



DO NOT WRITE IN THIS AREA

DO NOT WRITE IN THIS AREA

DO NOT WRITE IN THIS AREA

3 There were 2.1 million people living in Dubai in 2013  
1.75 million of these people were not born in Dubai.

- (a) Work out 1.75 as a percentage of 2.1  
Give your answer correct to 1 decimal place.

.....%  
(2)

The unit of currency in Dubai is the dirham.  
The exchange rate is £1 = 5.52 dirham.

The cost of a pair of running shoes in Dubai is 343 dirham.  
The cost of an identical pair of running shoes in the UK is £54.99

The pair of running shoes is more expensive in Dubai than in the UK.

- (b) How much more expensive?  
Give your answer to the nearest dirham.

.....dirham  
(3)

A plane flies a distance of 5522 km from London to Abu Dhabi in 7 hours 24 minutes.

- (c) Work out the average speed of the plane.  
Give your answer in kilometres per hour, correct to 3 significant figures.

..... kilometres per hour  
(3)

(Total for Question 3 is 8 marks)



4 Here is a kite  $ABCD$ .

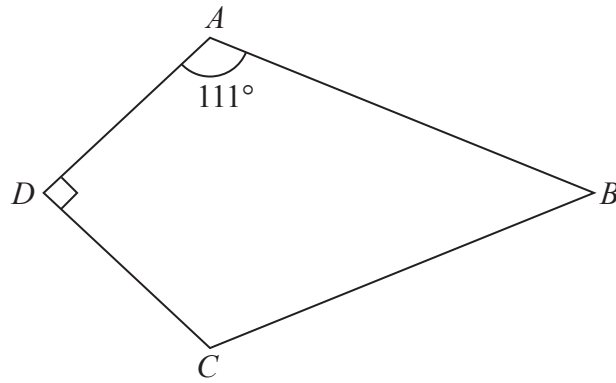

Diagram **NOT**  
accurately drawn

Angle  $DAB = 111^\circ$   
Angle  $ADC = 90^\circ$

(a) Work out the size of angle  $ABC$ .

.....  
(2)

DO NOT WRITE IN THIS AREA

DO NOT WRITE IN THIS AREA

DO NOT WRITE IN THIS AREA



DO NOT WRITE IN THIS AREA

DO NOT WRITE IN THIS AREA

DO NOT WRITE IN THIS AREA

Two of these kites are arranged so that a shorter side of one of the kites is placed on top of a shorter side of the other kite, as shown in the diagram below.

Diagram **NOT** accurately drawn

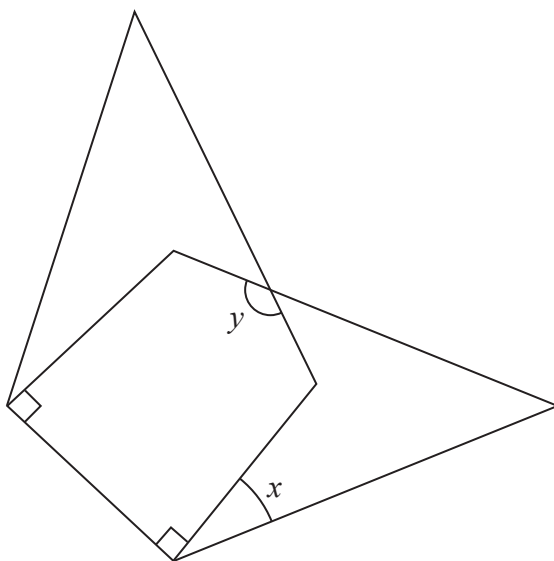

(b) Work out the size of angle  $x$ .

.....  
(2)

(c) Work out the size of angle  $y$ .

.....  
(3)

(Total for Question 4 is 7 marks)



5 (a) Complete the table of values for  $y = x^2 - 4x + 2$

$x$	-2	-1	0	1	2	3	4	5
$y$	14		2			-1	2	

(2)

(b) On the grid, draw the graph of  $y = x^2 - 4x + 2$  for values of  $x$  from -2 to 5

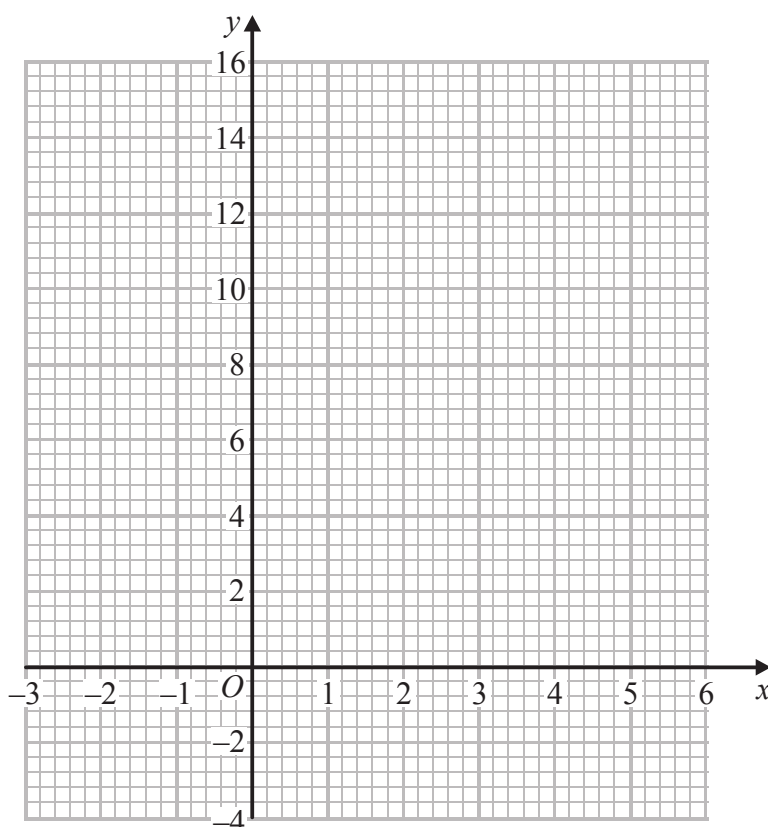

(2)

The point  $P(k, 4)$  where  $k > 0$  lies on the graph of  $y = x^2 - 4x + 2$

(c) Use your graph to find an estimate for the value of  $k$ .

(1)

(Total for Question 5 is 5 marks)





DO NOT WRITE IN THIS AREA

DO NOT WRITE IN THIS AREA

DO NOT WRITE IN THIS AREA

6 Here is a list of numbers written in order of size.

3    6     $x$      $y$

The numbers

have a median of 8

have a mean of 11

Find the value of  $x$  and the value of  $y$ .

$x =$  .....

$y =$  .....

**(Total for Question 6 is 3 marks)**



7 Here are two circles.

Diagram **NOT**  
accurately drawn

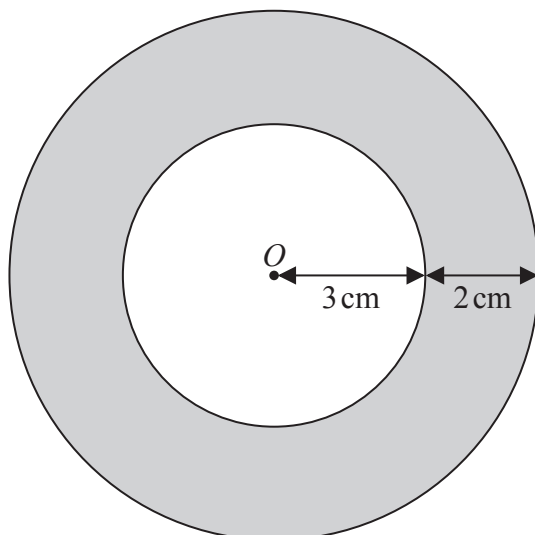

The circles have the same centre  $O$ .  
The radius of the inner circle is  $3\text{ cm}$ .  
The width of the shaded region between the inner circle and outer circle is  $2\text{ cm}$ .

Work out the area of the shaded region.  
Give your answer correct to 3 significant figures.

..... $\text{cm}^2$

(Total for Question 7 is 3 marks)

DO NOT WRITE IN THIS AREA

DO NOT WRITE IN THIS AREA

DO NOT WRITE IN THIS AREA



DO NOT WRITE IN THIS AREA

DO NOT WRITE IN THIS AREA

DO NOT WRITE IN THIS AREA

8 Louis makes a model of a plane.  
The wingspan of the model is 50 centimetres.  
The wingspan of the real plane is 80 metres.

- (a) Work out the scale of the model.  
Give your answer in the form 1:  $n$

1:.....  
(2)

The length of the real plane is 72 metres.

- (b) Work out the length of the model.  
Give your answer in centimetres.

..... centimetres  
(2)

**(Total for Question 8 is 4 marks)**



- 9 There are 30 apples in a box.  
The mean weight of these 30 apples is 120 grams.

There are 10 apples in a bag.  
The mean weight of these 10 apples is 95 grams.

Work out the mean weight of the 40 apples.

.....grams

**(Total for Question 9 is 3 marks)**

- 10 Solve  $4x + 3y = 6$

$$3x + 5y = -1$$

Show clear algebraic working.

$$x = \dots\dots\dots$$

$$y = \dots\dots\dots$$

**(Total for Question 10 is 4 marks)**



DO NOT WRITE IN THIS AREA

DO NOT WRITE IN THIS AREA

DO NOT WRITE IN THIS AREA

11 Here is a triangle  $QRS$ .

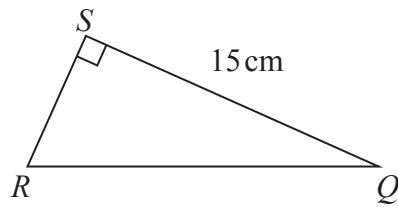

Diagram **NOT** accurately drawn

$SQ = 15 \text{ cm}$   
Angle  $RSQ = 90^\circ$   
Area of triangle  $QRS = 60 \text{ cm}^2$

Work out the size of angle  $SQR$ .  
Give your answer correct to 1 decimal place.

(Total for Question 11 is 4 marks)



12 The table gives some information about the incomes,  $\pounds I$ , of 100 people in the UK.

Income ( $\pounds I$ )	Frequency
$0 < I \leq 10000$	12
$10000 < I \leq 20000$	41
$20000 < I \leq 30000$	25
$30000 < I \leq 40000$	12
$40000 < I \leq 50000$	6
$50000 < I \leq 60000$	4

(a) Complete the cumulative frequency table.

Income ( $\pounds I$ )	Cumulative frequency
$0 < I \leq 10000$	12
$0 < I \leq 20000$	
$0 < I \leq 30000$	
$0 < I \leq 40000$	
$0 < I \leq 50000$	
$0 < I \leq 60000$	

(1)



DO NOT WRITE IN THIS AREA

DO NOT WRITE IN THIS AREA

DO NOT WRITE IN THIS AREA

(b) On the grid, draw a cumulative frequency graph for your table.

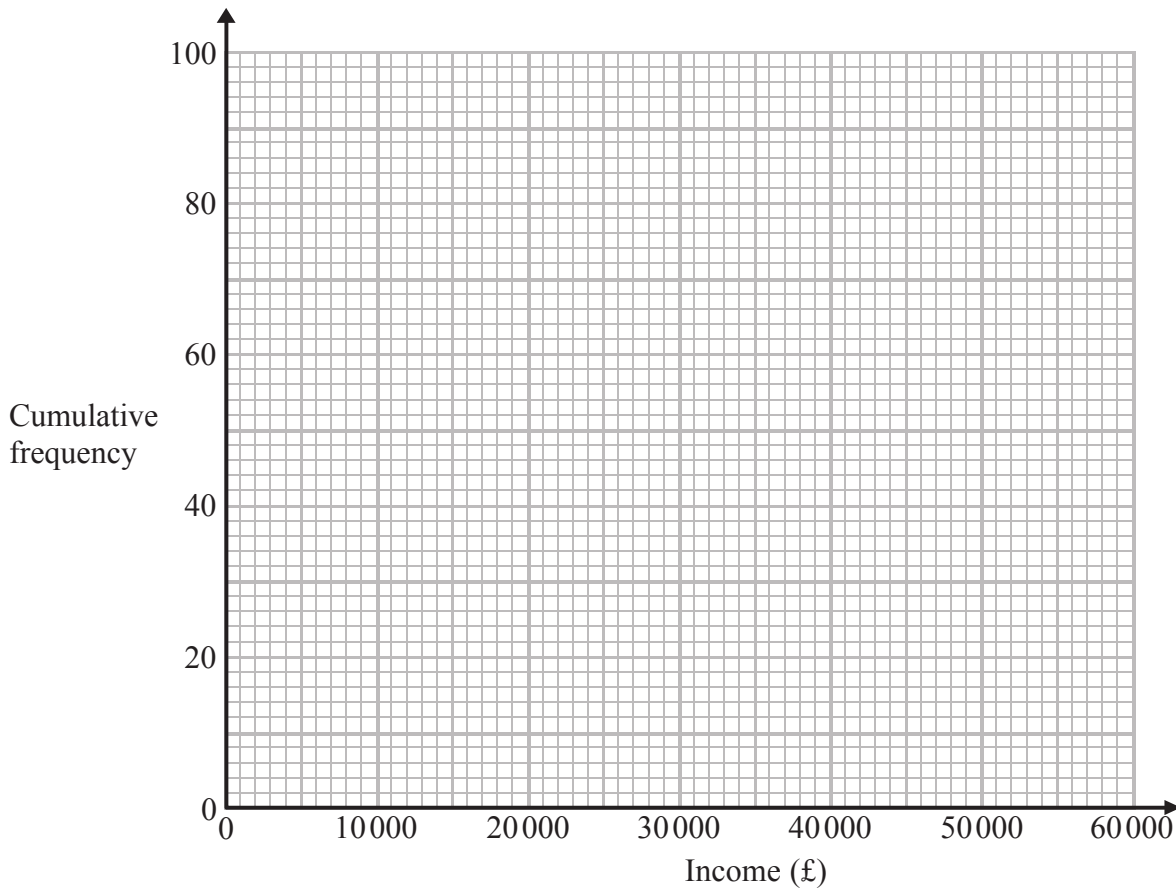

(2)

(c) Use your graph to find an estimate for

(i) the median,

£.....

(ii) the interquartile range.

£.....

(3)

(Total for Question 12 is 6 marks)



13 (a) Write 250 000 in standard form.

.....  
(1)

The radius of the planet Jupiter is  $6.99 \times 10^7$  metres.

The radius of the Earth is  $6.37 \times 10^6$  metres.

The volume of Jupiter is  $k$  times the volume of the Earth.

(b) Assuming that both planets are spheres, calculate the value of  $k$ .

Give your answer correct to 3 significant figures.

.....  
(3)

**(Total for Question 13 is 4 marks)**

DO NOT WRITE IN THIS AREA

DO NOT WRITE IN THIS AREA

DO NOT WRITE IN THIS AREA





DO NOT WRITE IN THIS AREA

DO NOT WRITE IN THIS AREA

DO NOT WRITE IN THIS AREA

14 (a) Solve  $2y + \frac{2 - 3y}{4} = \frac{1}{4}$

Show clear algebraic working.

$y = \dots\dots\dots$   
(3)

(b) Factorise  $3x^2 - 8x - 3$

$\dots\dots\dots$   
(2)

(c) Expand and simplify  $4x(x + 3) - (2x - 3)^2$

$\dots\dots\dots$   
(3)

(Total for Question 14 is 8 marks)



15 Naveed has two bags of tiles, bag A and bag B.

There are 10 tiles in bag A.  
7 of these tiles are red.  
The other 3 tiles are white.

There are 8 tiles in bag B.  
5 of these tiles are red.  
The other 3 tiles are white.

Naveed takes at random one tile from each bag.

(a) Work out the probability that the tiles are the same colour.

.....  
(3)

All 18 tiles are put in a box.  
Naveed takes at random one tile from the box.  
He does not replace the tile.  
Naveed then takes at random a second tile from the box.

(b) Work out the probability that both tiles are red.

.....  
(2)

(Total for Question 15 is 5 marks)



DO NOT WRITE IN THIS AREA

DO NOT WRITE IN THIS AREA

DO NOT WRITE IN THIS AREA

16 Solve  $2x^2 - 6x + 3 = 0$

Give your solutions correct to 3 significant figures.  
Show your working clearly.

---

(Total for Question 16 is 3 marks)

---



17 The diagram shows a prism.

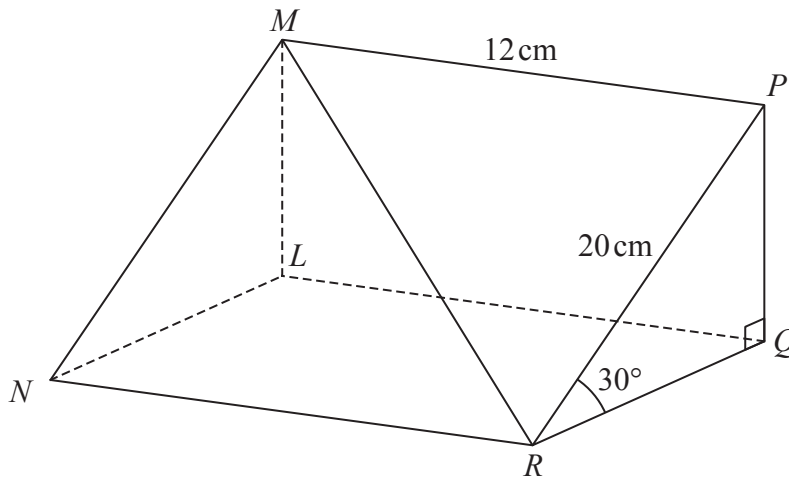

Diagram **NOT** accurately drawn

Triangle  $PQR$  is a cross section of the prism.

$$PR = 20 \text{ cm}$$

$$MP = 12 \text{ cm}$$

$$\text{Angle } PRQ = 30^\circ$$

$$\text{Angle } PQR = 90^\circ$$

Calculate the size of the angle that the line  $MR$  makes with the plane  $RQLN$ .

Give your answer correct to 1 decimal place.

DO NOT WRITE IN THIS AREA

DO NOT WRITE IN THIS AREA

DO NOT WRITE IN THIS AREA

(Total for Question 17 is 5 marks)



DO NOT WRITE IN THIS AREA

DO NOT WRITE IN THIS AREA

DO NOT WRITE IN THIS AREA

18 The Venn diagram shows a universal set  $\mathcal{E}$  and three sets  $X$ ,  $Y$  and  $Z$ .

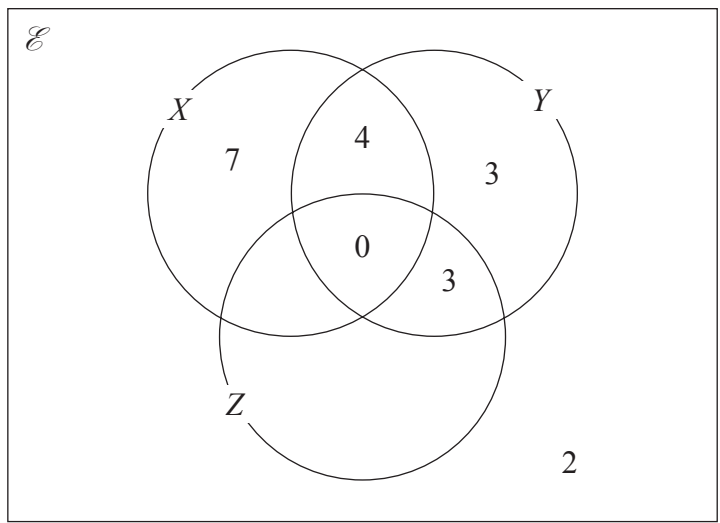

The numbers shown represent **numbers** of elements.

$$n(X') = 14$$

$$n(Z) = 14$$

(a) Complete the Venn diagram.

(2)

(b) Find the value of

(i)  $n(X \cup Z)$

.....

(ii)  $n(X \cap Y')$

.....

(2)

**(Total for Question 18 is 4 marks)**



19

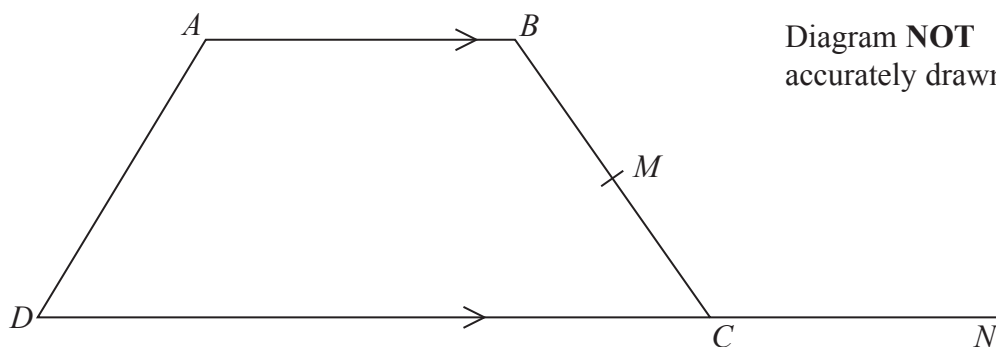

$AB$  is parallel to  $DC$

$$DC = 2AB$$

$M$  is the midpoint of  $BC$

$$\vec{AD} = 2\mathbf{b}$$

$$\vec{AB} = 4\mathbf{a}$$

- (a) Find  $\vec{BM}$  in terms of  $\mathbf{a}$  and  $\mathbf{b}$ .  
Give your answer in its simplest form.

(2)

$N$  is the point such that  $DCN$  is a straight line and  $DC : CN = 2 : 1$

- (b) Show that  $AMN$  is a straight line.

(2)

(Total for Question 19 is 4 marks)



DO NOT WRITE IN THIS AREA

DO NOT WRITE IN THIS AREA

DO NOT WRITE IN THIS AREA

20 The sketch shows the curve with equation  $y = x^2 + 4$  and the line with equation  $y = x + 10$

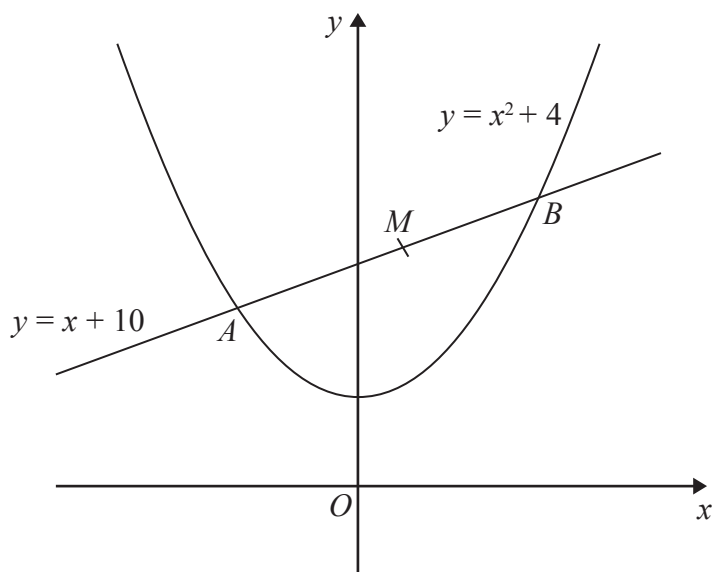

The line cuts the curve at the points  $A$  and  $B$ .

$M$  is the midpoint of  $AB$ .

Find the coordinates of  $M$ .  
Show clear algebraic working.

(Total for Question 20 is 6 marks)



21  $y = at^2 - 2at$

$$x = 2a\sqrt{t}$$

Express  $y$  in terms of  $x$  and  $a$ .

Give your answer in the form

$$y = \frac{x^p}{ma^3} - \frac{x^q}{na}$$

where  $p$ ,  $q$ ,  $m$  and  $n$  are integers.

---

(Total for Question 21 is 4 marks)

---

**TOTAL FOR PAPER IS 100 MARKS**

DO NOT WRITE IN THIS AREA

DO NOT WRITE IN THIS AREA

DO NOT WRITE IN THIS AREA

